

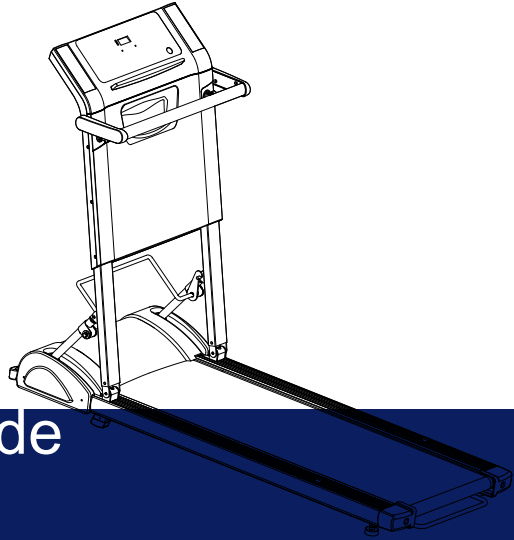

**HORIZON**  
FITNESS

**Evolve**



# TREADMILL

## Owner's Guide

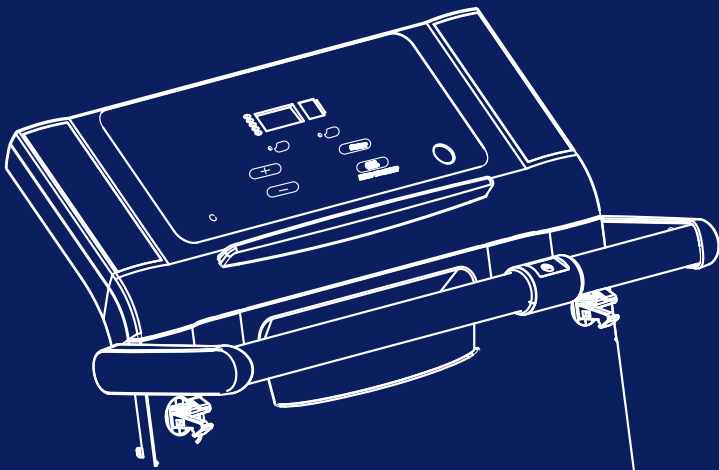



# TABLE OF CONTENTS

SAFETY INSTRUCTIONS .....	3
UNFOLDING / FOLDING .....	6
MOVING / STORAGE .....	7
LEVELING, POWER & EMERGENCY STOP .....	8
KNOW YOUR TREADMILL .....	9
GETTING STARED .....	10
DISPLAY .....	11
USING PROGRAMS .....	12
TROUBLESHOOTING .....	13
COMMON QUESTIONS .....	15
MAINTENANCE PROCEDURES .....	17
EXERCISE GUIDELINES .....	18
DEVELOPING A FITNESS PROGRAM & IMPORTANCE OF WARM UP/ COOL DOWN .....	19
FITNESS GOALS .....	20
WEEKLY LOG SHEETS .....	21
MONTHLY LOG SHEETS .....	22
LIMITED HOME USE WARRANTY .....	23



## CAUTION

Read all precautions and instructions in this manual before using this equipment.

Save this manual for future reference.

# IMPORTANT SAFETY INSTRUCTIONS

## SAVE THESE INSTRUCTIONS

Read all instructions before using this treadmill. When using an electrical product, basic precautions should always be followed, including the following: Read all instructions before using this HORIZON FITNESS treadmill



**WARNING!** Connect this exercise product to a properly grounded outlet only. See grounding instructions.

## GROUNDING INSTRUCTIONS

This product must be grounded. If a treadmill should malfunction or breakdown, grounding provides a path of least resistance for electrical current to reduce the risk of electrical shock. This product is equipped with a cord having an equipment-grounding conductor and a grounding plug. The plug must be plugged into an appropriate outlet that is properly installed and grounded in accordance with local codes and ordinances.

**DANGER!** Improper connection of the equipment-grounding conductor can result in a risk of electric shock. Check with a qualified electrician or serviceman if you are in doubt as to whether the product is properly grounded. Do not modify the plug provided with the product. If it will not fit the outlet, have a proper outlet installed by a qualified electrician.

This product is for use on a nominal 220-240 volt circuit, and has a grounding plug that looks like the plug illustrated below. A temporary adapter such as the one illustrated below may be used to connect this plug to a 2-pole receptacle as shown, if a properly grounded outlet is not available. The temporary adapter should be used only until a properly grounded outlet can be installed by a qualified electrician. The green colored rigid ear, lug, or the like extending from the adapter must be connected to a permanent ground such as a properly grounded outlet box cover. Whenever the adapter is used, it must be held in place by a metal screw.

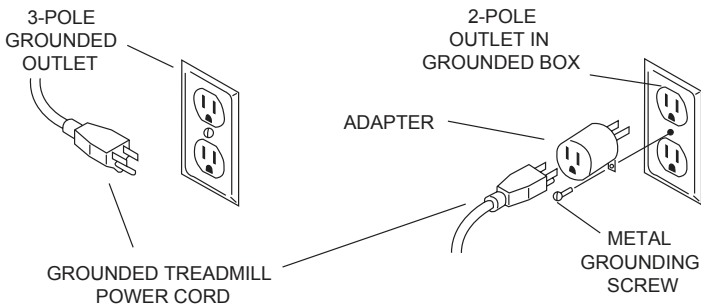



**WARNING!** To reduce the risk of burns, fire, electrical shock or injury to persons:

- Never use the treadmill before securing the safety tether clip to your clothing.
- If you experience chest pains, nausea, dizziness, or shortness of breath, stop exercising immediately and consult your physician before continuing.
- Do not wear clothes that might catch on any part of the treadmill.
- Keep power cord away from heated surfaces.
- Keep children off of treadmill at all times.
- Do not use treadmill outdoors.
- Unplug treadmill before moving it.
- Do not remove the treadmill motor covers or roller covers. Service should be performed only by an authorized Horizon Fitness service provider.
- treadmill should be plugged into a dedicated circuit.
- At no time should more than one person be on treadmill while in operation.

### **CHILDREN**

- Keep children off your treadmill at all times.
- When the treadmill is in use, young children and pets should be kept at least 10 feet away.

### **CLEANING**

- Clean with soap and slightly damp cloth only; never use solvents.

### **CAUTION!**

Folding mechanism will be damage if applying any lubricant.

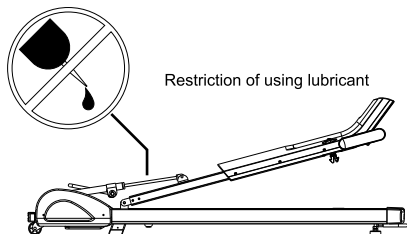

### **OTHER SAFETY TIPS FOR YOUR HORIZON FITNESS TREADMILL**



**CAUTION!** If you experience chest pains, nausea, dizziness or shortness of breath, stop exercising immediately and consult your physician before continuing.

- Do not wear clothing that might catch on any part of the treadmill.
- Read this Owner's Guide before operating this treadmill.

## **OPERATION**

To reduce the risk of damaging important components on your treadmill, it is strongly recommended that your treadmill is plugged into a dedicated 20amp outlet, without the use of an additional extension cord.

It is essential that your treadmill is used only indoors, in a climate controlled room. If your treadmill has been exposed to colder temperatures or high moisture climates, it is strongly recommended that the treadmill is warmed up to room temperature before first time use. Failure to do so may cause premature electronic failure.

**CONGRATULATIONS!** on choosing an Elite Series treadmill.

You've taken an important step in developing and sustaining an exercise program! Your Horizon Fitness treadmill is a tremendously effective tool for achieving your personal fitness goals. Regular use of your Horizon Fitness treadmill can improve the quality of your life in so many ways.

Here are just a few of the health benefits of aerobic exercise:

- Weight Loss
- A Healthier Heart
- Improved Muscle Tone
- Increased Daily Energy Levels
- Reduced Stress
- Help In Countering Anxiety and Depression
- An Improved Self Image

The key to reaping these benefits is to develop the exercise habit. Your new Horizon Fitness treadmill will help you eliminate the obstacles that prevent you from getting in your exercise time. Inclement weather and darkness won't interfere with your workout when you use your Horizon Fitness treadmill in the comfort of your home. This manual provides you with basic information for using and enjoying your new machine. A more complete knowledge of your new Horizon Fitness treadmill will assist you in realizing your goal of a healthy lifestyle.



**CAUTION:** BEFORE BEGINNING ANY EXERCISE PROGRAM, ALWAYS CONSULT YOUR PHYSICIAN. IF YOU EXPERIENCE CHEST PAINS, NAUSEA, DIZZINESS OR SHORTNESS OF BREATH, STOP EXERCISING AND CONSULT YOUR PHYSICIAN BEFORE CONTINUING.

## IMPORTANT: PLEASE READ BEFORE USE!

### UNFOLDING

The treadmill was folded in the carton when purchased. Follow these steps to unfold the treadmill.

1. Press and hold both **LOCKBUTTONS** with your thumbs.
2. Carefully lift the **CONSOLE MODULE** upward until it is in the upright position.
3. Pull the **LOCKING BAR** upward until it is tight.
4. Gently pull the **FRONT HANDLE BAR** downward.

#### CAUTION:

Do not use the treadmill if the **LOCKING BAR** is not tight.

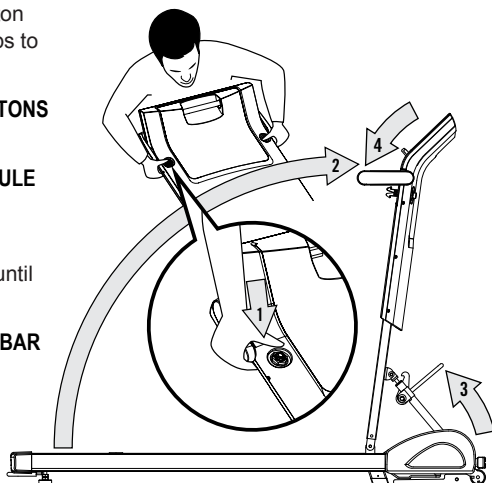

### FOLDING

Follow these steps to fold the treadmill.

1. Gently pull the **FRONT HANDLEBAR** upward.
2. Pull the **LOCKING BAR** downward to release the lock.
3. Carefully pull the **CONSOLE MODULE** downward until it rests flat on the treadmill deck.
4. Press down on the **CONSOLE MODULE** until both locks engage.

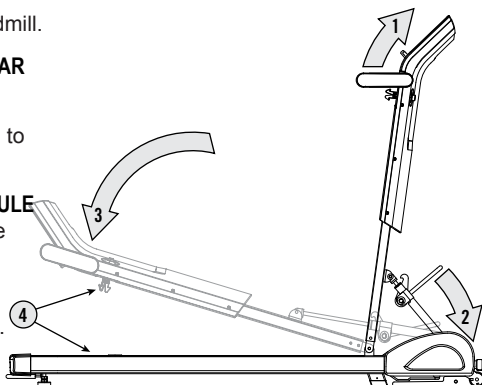

## MOVING AND STORAGE



Our treadmills can be heavy. Use care and additional help if necessary when moving. Do not attempt to move or transport treadmill unless both the lock latches are secured. Failure to follow these instructions could result in injury.

### MOVING / STORAGE

This treadmill has a pair of transport wheels built under the base frame. To move, make sure the treadmill is folded down and securely latched. Then, firmly grasp the lifting handlebar, lift the treadmill up and roll. This treadmill can be stored horizontally (under a bed) or vertically (against a wall).

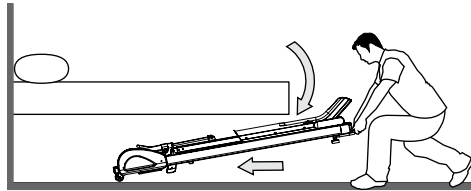

To store underneath a bed, firmly grasp the lifting bar and move the treadmill. Gently lower and push the treadmill under the bed. (See illustration above)

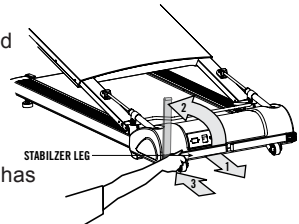

### CAUTION:

To prevent damage to the treadmill, make sure the area has enough space to store the treadmill.

This treadmill is equipped with two STABILIZER LEGS on the front side. To store the treadmill vertically, follow these steps:

1. To stand the treadmill up, pull the STABILIZER LEGS outward.
2. Turn the STABILIZER LEGS so they face upward.
3. Push the STABILIZER LEGS back in to lock them in place.
4. Place the treadmill close to wall with the STABILIZER LEGS facing the wall. Carefully lift the treadmill up using the LIFTING BAR
5. Pull the STABILIZER BRACKET upward.
6. Rotate the STABILIZER BRACKET down all the way to the floor. The STABILIZER BRACKET will automatically lock in place.
7. To put the treadmill back down, pull the STABILIZER BRACKET towards you and rotate it upward until it locks.
8. Follow the steps above in reverse order to completely put the treadmill back down.

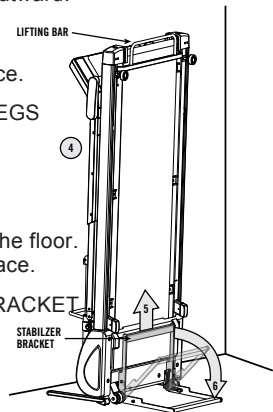



## **LEVELING**

The treadmill should be level for optimum use. Once you have placed the treadmill where you intend to use it, raise or lower the adjustable levelers located on the treadmill base frame. Once you have leveled the treadmill, lock the levelers in place by tightening the nuts against the frame. To assure the treadmill is level, a carpenter's level is recommended.

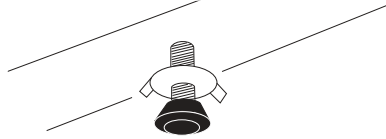

## **TURN POWER ON**

Make sure that your treadmill is properly connected to a power outlet. The on/off switch is located next to the power cord. Flip this switch to the 'on' position, so that the switch is lit. You will hear a beep and the console will light up.

## **SAFETY KEY**

Your treadmill will not start unless the safety key is placed on the safety key holder. Attach the clip end securely to your clothing. This safety key is designed to cut the power to the treadmill if you should fall. **NEVER USE THE TREADMILL WITHOUT SECURING THE SAFETY KEY CLIP TO YOUR CLOTHING. PULL ON THE SAFETY KEY CLIP FIRST TO MAKE SURE IT WILL NOT COME OFF YOUR CLOTHING.**

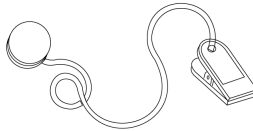

## **DO NOT STAND ON THE BELT**

While you are preparing to use the treadmill, do not stand on the belt. Place your feet on the side rails before starting the treadmill. Start walking on the belt only after the belt has begun to move. Never start the treadmill at a fast running speed and attempt to jump on!

# KNOW YOUR TREADMILL

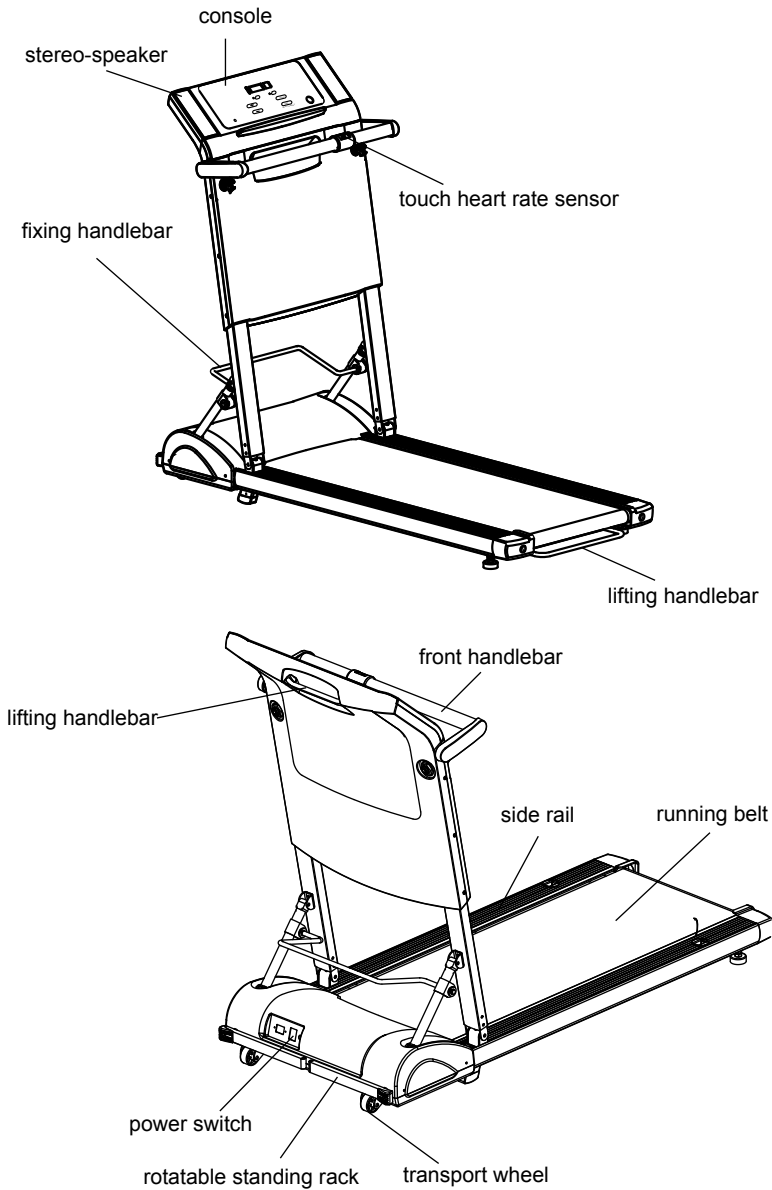

# GETTING STARTED

## **QUICK START UP**

Simply press the Start button to begin exercising.

## **ADJUSTING SPEED**

Adjust your desired speed using the + or - buttons.

## **PAUSE**

Press the Stop button to pause your workout.

## **RESET**

Press and hold the Stop button to reset the treadmill.

## **AUDIO STATION**

The music input jack is compatible with any kind of music player such as MP3, CD, cassette, etc. To use it, plug the accessory cord into the music input jack on the console, then plug the other side into the headphone jack on your music player.

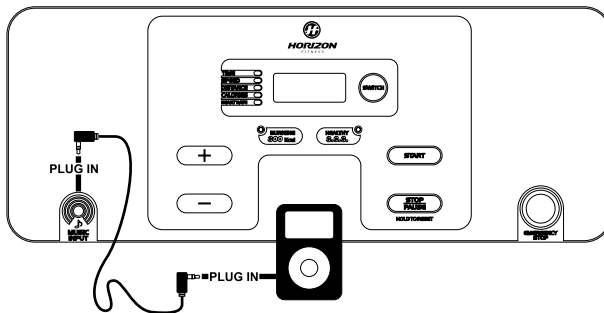

# DISPLAY

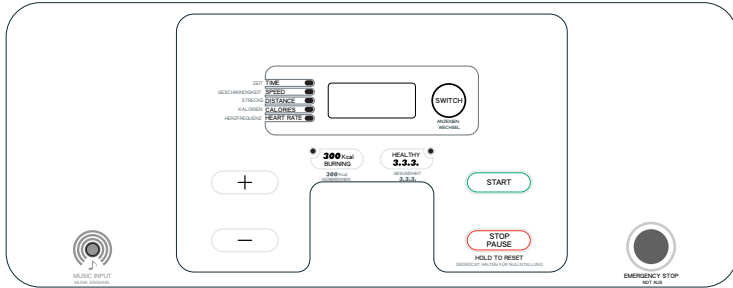

## **SWITCH**

Use to view alternative information such as Time, Speed, Distance, Calories and Heart rate during your workout.

## **TIME**

Shown as Minutes:Seconds. View the time remaining or the time elapsed in your workout.

## **SPEED**

Shown in the top right-hand display window. Indicates how fast your walking or running surface is moving.

## **DISTANCE**

Miles traveled during your workout.

## **CALORIES**

Total Calories burned during your workout.

## **HEART RATE**

The user's heart rate can be easily detected by slightly putting finger on the sensor pad. Heart rate will be displayed if the heart rate sensor is being used. The reading is measured in beats per minute.

## USING PROGRAMS

There are two presetting programs on the treadmill, you may simply press any of quick program key to start the program.

- 300 Kcal BURNNING

The program will adjust the speed to burn 300 Kcal of your calories during your workout. Entire 30 minutes of the workout include 2 minutes warm up at first and 1 minute cool down at last. When you use this program, the console will automatically switch to Calories display and then count down from 300.

### British

Program stage	Warm up	1	2	3	4	5	6	7	8	9	Cool down
Time segment (min.)	2.5	3.5	5.4	6.0	5.0	5.4	6.0	5.4	6.0	5.0	2.5

### Metric

Program stage	Warm up	1	2	3	4	5	6	7	8	9	Cool down
Time segment (min.)	4.0	5.6	8.6	9.6	8.0	8.6	9.6	8.6	9.6	8.0	4.0

- HEALTHY 3.3.3.

"Healthy 333" is a slogan for exercise to keep your health by this simple rule. "To do exercise 3 times a week, 30 minutes every time and reach 130 bpm of pulse during the workout". Therefore, you may use this program 3 times a week. The program will adjust according speed to make your pulse reaching 130 bpm during the workout. Please put your finger on the touch heart rate sensor when you use this program, the console will automatically switches to heart rate display and reads your pulse to arrange the appropriate speed.

### Healthy

Time Segment (min.)	0 ~ 3	4 ~ 6	7 ~ 9	11 ~ 12	13 ~ 15	16 ~ 18	19 ~ 21	22 ~ 24	25 ~ 27	28 ~ 30
Pulse Range	warm up	100~130	130~160	100~130	130~160	100~130	130~160	100~130	130~160	cool down

## TROUBLESHOOTING YOUR TREADMILL

Horizon Fitness treadmills are designed to be reliable and easy to use. However, if you experience a problem, please reference the troubleshooting guide listed below.

**PROBLEM:** The console does not light up.

**SOLUTION:** Verify that the power cord is plugged in properly to the outlet, and that the treadmill switch is turned on.

**PROBLEM:** The treadmill circuit breaker trips during a workout.

**SOLUTION:** Verify that the treadmill is plugged into a dedicated 20amp circuit.

**NOTE:** no extension cord.

**PROBLEM:** The running belt does not stay centered during a workout.

**SOLUTION:** Verify that the treadmill is on a level surface. Verify that the belt is properly tightened (refer to Centering The Belt.)

**PROBLEM:** The treadmill makes a clicking noise towards the front of the machine while walking or running on it.

**SOLUTION:** For optimum use, the treadmill needs to be level. Refer to the section on leveling your treadmill.

## HEART RATE TROUBLESHOOTING

Check your exercise environment for sources of interference such as fluorescent lights, computers, or appliances containing large motors. These items may cause erratic heart rate readouts.

You may experience an erratic readout under the following conditions:

- Putting finger on the sensor pad too tight. Try to maintain moderate pressure while holding onto the heart rate handlebars. Putting finger on the sensor pad.

- Constant movement and vibration due to constantly Putting finger on the sensor pad.  
If you are receiving erratic heart rate readouts, try to only Putting finger on the sensor pad. enough to monitor your heart rate.
- When you are breathing heavily during a workout.
- Anyone with heavy arrhythmia.
- Anyone with arteriosclerosis or peripheral circulation disorder.
- Anyone whose skin on the measuring palm fingertip is especially thick.

**PROBLEM:** There is no heart rate reading.

**SOLUTION:** If you are using the chest strap, there may be a poor connection between the electrodes and the skin. Remoisten the electrodes with water.

**SOLUTION:** The chest strap may not be positioned properly. Reposition the chest strap. It may be necessary to experiment with the fit and position of the chest strap.

**SOLUTION:** Verify that the distance between the chest strap and the console is not beyond the recommended range of 36 inches.

If the above troubleshooting section does not remedy the problem, discontinue use and turn the power off.

Please consult your local doalar for futher assistance

## COMMON PRODUCT QUESTIONS

### ***ARE THE SOUNDS MY TREADMILL MAKES NORMAL?***

All treadmills make a certain type of thumping noise due to the belt riding over the rollers, especially new treadmills. This noise will diminish over time, although may not totally go away. Over time, the belt will stretch, causing the belt to ride smoother over the rollers.

### ***WHY IS THE TREADMILL I HAD DELIVERED LOUDER THAN THE ONE AT THE STORE?***

All fitness products seem quieter in a large store showroom because there is generally more background noise than in your home. Also, there will be less reverberation on a carpeted concrete floor than on a wood overlay floor. Sometimes a heavy rubber mat will help reduce reverberation through the floor. If a fitness product is placed close to a wall, there will be more reflected noise.

### ***WHEN SHOULD I BE WORRIED ABOUT A NOISE?***

As long as the sounds your treadmill makes are no louder than a normal conversational tone of voice, it is considered normal noise. If your treadmill is louder than this, you may want to call localdealer. Sometimes an initial diagnosis can be made over the phone.

## MAINTENANCE

### ***WHAT KIND OF ROUTINE MAINTENANCE IS REQUIRED?***

We use sealed bearings throughout our treadmill so lubrication is not needed. The most important maintenance step is to simply wipe your perspiration off the treadmill after each use.

### ***HOW DO I CLEAN MY HORIZON FITNESS TREADMILL?***

Clean with soap and water only. Never use solvents on plastic parts.

### ***HOW OFTEN DOES MY HORIZON FITNESS TREADMILL NEED TO BE LUBRICATED?***

Our testing has shown that under normal use, your treadmill will work properly without a breakdown in the lubrication system for years. However, to keep your treadmill running without problems, we recommend that lubrication be added once a year. Please use the lubrication provided by Horizon Fitness only.



## **TENSIONING THE BELT**

If you can feel a slipping sensation when running on the treadmill, the running belt must be tightened. In most cases, the belt has stretched from use, causing the belt to slip. This is a normal and common adjustment. To eliminate this slipping, tension both the rear roller bolts with the appropriate size allen wrench, turning it 1/4 TURN to the right as shown. Try the treadmill again to check for slipping.

Repeat if necessary, but NEVER TURN the roller bolts more than 1/4 turn at a time. the belt tension is set properly when the running belt is 1/4 of an inch from the deck.

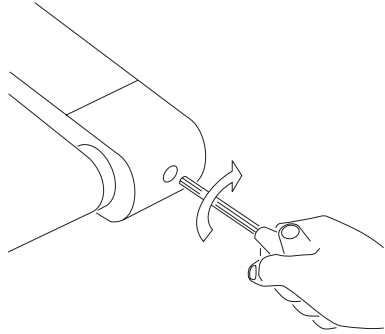

## **CENTERING THE BELT**

If the running belt is too far to the right side, use the supplied Allen wrench to turn the right tension bolt clockwise 1/4 turn at a time until the belt remains centered during use.

If the running belt is too far to the left side, turn the left tension bolt clockwise 1/4 turn at a time until the belt remains centered during use.

### **IF THE BELT IS TOO FAR TO THE LEFT SIDE:**

- Turn the left roller bolt 1/4 turn clockwise (tighten).

### **IF THE BELT IS TOO FAR TO THE RIGHT SIDE:**

- Turn the right roller bolt 1/4 turn clockwise (tighten).

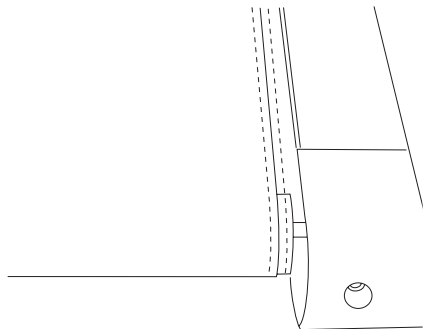

# MAINTENANCE

Cleanliness of your treadmill and its operation environment will keep maintenance problems and service calls to a minimum. For this reason, we recommend that the following preventive maintenance schedule be followed.

## AFTER EACH USE (DAILY)

Clean and inspect, following these steps:

- Turn off the treadmill with the on/off switch, then unplug the power cord at the wall outlet.
- Wipe down the running belt, deck, motor cover, and console casing with a damp cloth. Never use solvents, as they can cause damage to the treadmill.
- Inspect the power cord. If the power cord is damaged, contact Fitness Gear.
- Make sure the power cord is not underneath the treadmill or in any other area where it can become pinched or cut.
- Check the tension and alignment of the running belt. Make sure that the treadmill belt will not damage any other components on the treadmill by being misaligned.

## EVERY WEEK

Clean underneath the treadmill, following these steps:

- Turn off the treadmill with the on/off switch, then unplug the power cord at the wall outlet.
- Fold the treadmill into the upright position, making sure that the lock latch is secure.
- Move the treadmill to a remote location. • Wipe or vacuum any dust particles or other objects that may have accumulated underneath the treadmill.
- Return the treadmill to its previous position.

## EVERY MONTH - IMPORTANT!

- Turn off the treadmill with the on/off switch, then unplug the power cord at the wall outlet.
- Inspect all assembly bolts of the machine for proper tightness.
- Turn off the treadmill and wait 60 seconds.
- Remove the motor cover. Wait until ALL LED lights turn off.
- Clean the motor and lower board area to eliminate any lint or dust particles that may have accumulated. Failure to do so may result in premature failure of key electrical components.
- Vacuum and wipe down the belt with a damp cloth. Vacuum any black/white particles that may accumulate around the unit. These particles may accumulate from normal treadmill use.

## EVERY 6 MONTHS OR 150 MILES

It is necessary to lubricate your treadmill running deck every six months or 150 miles to maintain optimal performance. Once the treadmill reaches 150 miles, the console will display the message "LUBE" or LUBE BELT". The treadmill will not operate while the message is showing. Hold Stop for 5 seconds to suspend message for 5 miles. Your treadmill came with a bottle of lubricant which can be used for two applications. If you need lubricant, contact Fitness Gear. Only use lubricant provided by Fitness Gear.

- Turn off the treadmill with the on/off switch, then unplug the power cord at the wall outlet.
- Loosen both the rear roller bolts. (For best results, place two removable marks on both sides of the frame and note roller position). Once the belt is loosened, take the bottle of lubricant and apply it to the entire top surface of the running deck. Tighten both rear roller bolts (matching up the marks for proper position) to original position. After you have applied lubricant, plug in the power cord, insert the safety key, start the treadmill and walk on the belt for two minutes to spread the lubricant.
- Lubricate the air shocks with Teflon based spray.
- Once lubrication is complete, reset the console by pressing and holding 'STOP' and Speed '+' buttons for 5 seconds. Please contact Fitness Gear with questions about applying lubricant to your treadmill.

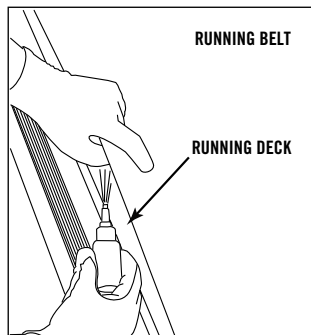

# EXERCISE GUIDELINES

Always consult your physician before beginning an exercise program.

## ***HOW OFTEN?***

The American Heart Association recommends that you exercise at least 3 to 4 days per week to maintain cardiovascular fitness. If you have other goals such as weight or fat loss, you will achieve your goal faster with more frequent exercise. Whether it's 3 days or 6 days, remember that your ultimate goal should be to make exercise a lifetime habit. Many people are successful staying with a fitness program if they set aside a specific time of day to exercise. It doesn't matter whether it's in the morning before your shower, during lunch hour or while watching the evening news. What's more important is that it's a time that allows you to keep a schedule, and a time when you won't be interrupted. If you are to be successful with your fitness program, you have to make it a priority in your life. So decide on a time, pull out your day planner and pencil in your exercise times for the next month!

## ***HOW LONG?***

For aerobic exercise benefits, it's recommended that you exercise from between 24 and 32 minutes per session. But start slowly and gradually increase your exercise times. If you've been sedentary during the past year, it may be a good idea to keep your exercise times to as little as five minutes initially. Your body will need time to adjust to the new activity. If your goal is weight loss, a longer exercise session at lower intensities has been found to be most effective. A workout time of 48 minutes or more is recommended for best weight loss results.

## ***HOW HARD?***

How hard you workout is also determined by your goals. If you use your Horizon Fitness treadmill to prepare for a 5K run, you will probably work out at a higher intensity than if your goal is general fitness. Regardless of your long term goals, always begin an exercise program at low intensity. Aerobic exercise does not have to be painful to be beneficial! There are two ways to measure your exercise intensity. The first is by monitoring your heart rate, and the second is by evaluating your perceived exertion level (this is simpler than it sounds!).

## ***PERCEIVED EXERTION LEVEL***

The second and simpler way to gauge your exercise intensity is to evaluate your perceived exertion level. While exercising if you are too winded to maintain a conversation without gasping, you are working out too hard. A good rule of thumb is to work to the point of exhilaration, not exhaustion. If you cannot catch your breath, it's time to slow down. Always be aware of other warning signs of overexertion.

## DEVELOPING A FITNESS PROGRAM



### **STRETCH FIRST**

Before using your Horizon Fitness product, it is best to take a few minutes doing a few gentle stretching exercises. Stretching prior to exercise will improve flexibility and reduce chances of exercise related injury. Ease into each of these stretches with a slow gentle motion. Do not stretch to the point of pain. Make sure not to bounce while doing these stretches.

### **WALL PUSH**

Stand near a wall with the toes of one foot about 18" from the wall, and the other foot about 12" behind the other foot. Lean forward, pushing against the wall with your palms. Keep your heels flat and hold this position for a count of 15 seconds. Make sure that you do not bounce while stretching. Alternate positions of your feet and repeat for a total of 8 repetitions.

### **STANDING QUADRICEPS STRETCH**

Using a wall to provide balance, grasp your left ankle with your left hand and hold your foot against the back of your thigh for a count of 15 seconds. Repeat with your right ankle and hand, and continue alternating for a total of 8 repetitions.

### **SEATED TOE TOUCH**

Sit on the floor with your legs together and straight out in front of you. Do not lock your knees. Extend your fingers towards your toes and hold for a count of 15 seconds. Make sure that you do not bounce while stretching. Sit upright again. Repeat for a total of 8 repetitions.

## THE IMPORTANCE OF WARM UP AND COOL DOWN

### **WARM UP**

The first 2 to 5 minutes of a workout should be devoted to warming up. The warm-up will limber your muscles and prepare them for more strenuous exercise. Make sure that you warm-up on your Horizon Fitness product at a slow pace.

### **COOL DOWN**

Never stop exercising suddenly! A cool-down period allows your heart to readjust to the decreased demand. Make sure that your cool down period consists of a very slow pace to allow your heart rate to lower. After the cool-down, repeat the stretching exercises listed above to loosen and relax your muscles.

# ACHIEVING YOUR FITNESS GOALS

An important step in developing a long term fitness program is to determine your goals. Is your primary goal for exercising on your Horizon Fitness treadmill to lose weight? Improve muscle? Burn Stress? Prepare for the spring racing schedule? Knowing what your goals are will help you develop a more successful exercise program. Below are some common exercise goals:

- Weight Loss
- Improve Body Shape and Tone
- Increased Energy Level
- Improved Sports Performance
- Improved Cardiovascular Endurance
- Weight Maintenance
- Strengthen Leg Muscles
- Improved Sleep Patterns
- Stress Reduction

If possible try to define your personal goals in precise, measurable terms, and then put your goals in writing. The more specific you can be, the easier it will be to track your progress. If your goals are long term, divide them up into monthly and weekly segments. Longer term goals can lose some of the immediate motivation benefits. Short term goals are easier to achieve. Your Horizon Fitness treadmill console provides you with several readouts that can be used to record your progress. You can track Distance, Calories or Time. Time is the most important and useful of test functions.

## ***KEEPING AN EXERCISE DAIRY***

Photocopy the weekly and monthly log sheets on the following pages to make your personal exercise log book. As time goes by you'll be able to look back with pride at the work you've done. As your fitness improves, you can look back and see how far you've come.

# WEEKLY LOG SHEET

WEEK # _____		WEEKLY GOAL: _____			
DAY	DATE	DISTANCE	CALORIES	TIME	COMMENTS
SUN					
MON					
TUES					
WED					
THUR					
FRI					
SAT					
WEEKLY TOTALS					

WEEK # _____		WEEKLY GOAL: _____			
DAY	DATE	DISTANCE	CALORIES	TIME	COMMENTS
SUN					
MON					
TUES					
WED					
THUR					
FRI					
SAT					
WEEKLY TOTALS					

# MONTHLY LOG SHEET

MONTH _____		MONTHLY GOAL: _____	
WEEK #	DISTANCE	CALORIES	TIME
MONTHLY TOTALS			

MONTH _____		MONTHLY GOAL: _____	
WEEK #	DISTANCE	CALORIES	TIME
MONTHLY TOTALS			

## LIMITED HOME USE WARRANTY

### ***FRAME • LIFETIME***

Horizon Fitness warrants the frame against defects in workmanship and materials for the lifetime of the original owner.

### ***ELECTRONICS & PARTS***

Horizon Fitness warrants the electronic components and all original parts for a period from the date of original purchase, so long as the device remains in the possession of the original owner.

### ***LABOR***

Horizon Fitness shall cover the labor cost for the repair of the device for a period from the date of the original purchase, so long as the device remains in the possession of the original owner.

### ***EXCLUSIONS AND LIMITATIONS***

This warranty applies only to the original owner and is not transferable. The warranty is expressly limited to the repair or replacement of a defective frame, electronic component or defective part and is the sole remedy of the warranty. The warranty does not cover normal wear and tear, improper assembly or maintenance, or installation of parts or accessories not originally intended or compatible with the treadmill as sold. The warranty does not apply to damage or failure due to accident, abuse, corrosion, discoloration of paint or plastic, or neglect. Horizon Fitness shall not be responsible for incidental or consequential damages. All returns must be pre-authorized by Horizon Fitness. 'Horizon Fitness' obligation under this warranty is limited to replacing or repairing, at 'Horizon Fitness' option, the product at one of its authorized service centers. An Horizon Fitness authorized service center must receive all products for which a warranty claim is made. These products must be received with all freight and other transportation charges prepaid, accompanied by sufficient proof of purchase. Parts and electronic components reconditioned to As New Condition by Horizon Fitness or its vendors may sometimes be supplied as warranty replacement parts and constitute fulfillment of warranty terms.

Please consult your local dealer for more warranty details.

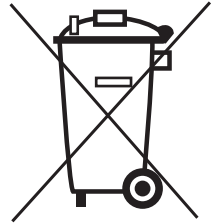

**D:**

Entsorgungshinweis

Horizon Fitness/Vision Fitness - Produkte sind recyclebar. Führen Sie das gerät am Ende der Nutzungsdauer einer sachgerechten Entsorgung zu (örtliche Sammelstelle).

**GB:**

Waste Disposal

Horizon Fitness/Vision Fitness products are recyclable. At the end of its useful life please dispose of this article correctly and safely ( local refuse sites).

**F:**

Remarque relative à la gestion des déchets Les produits Horizon Fitness/Vision Fitness sont recyclables. A la fin sa durèe d'utilisation, remettez l'appareil à un centre de gestion de déchets correct (collecte locale).

**NL:**

Verwijderingsaanwijzing

Horizon Fitness/Vision Fitness producten zijn recyclebaar. Breng het apparaat aan het einde van de gebruiksduur naar een vaekundig verzampelbunt voor recycling.

**E:**

Informaciones para la evacuaciòn

Los productos de Horizon Fitness/Vision Fitness son reciclables. Cuando se termina la vida ùtil de un aparato o una màquina, entrèguelos an una impresa local de eliminaciòn de residuos para su reciclaje.

**I:**

Indicazione sullo smaltimento

I prodotti Horizon Fitness/Vision Fitness sono riciclabill. Quando l'apparecchio non servirà più, portatelo in un apposito punto di raccolta della Vostra città (Punti di raccolta comunall).

**PL:**

Wskazòwka dotyczàca usuwania odpadów.

Producty firmy Horizon Fitness/Vision Fitness podlegajà recyklingowi. Pod koniec okresu o'ywatnoÈcl pros'z oddac urzàdzenie do wlaÈciwego punktu usuwania odpadów (lokalny punkt zbiorczy).

